



"VERIS V3" GLAZED ALUMINUM PIVOT DOOR SINGLE w/ or w/out SIDELITE(S) w/ TRANSOM OUTSWING "IMPACT"

GENERAL NOTES

1. This product has been evaluated and is in compliance with the 8th Edition (2023) Florida Building Code (FBC) structural requirements including the "High Velocity Hurricane Zone" (HVHZ).
2. Product anchors shall be as listed and spaced as shown on details. Anchor embedment to base material shall be beyond wall dressing or stucco.
3. When used in the "HVHZ", this product complies with Section 1626 of the Florida Building Code and does not require an impact resistant covering.
4. For 2x stud framing construction, anchoring of these units shall be the same as that shown for 2x buck masonry construction.
5. Site conditions that deviate from the details of this drawing require further engineering analysis by a licensed engineer or registered architect.
6. This product does not meet the water infiltration requirements for the "HVHZ" and shall be installed only in non-habitable areas or at habitable locations protected by an overhang or canopy such that the angle between the edge of canopy or overhang to sill is less than 45 degrees.
7. Aluminum components, including fasteners, shall meet the requirements of FBC Section 2003.
8. Gaskets shall comply with FBC Section 2411.3.4.

TABLE OF CONTENTS	
SHEET #	DESCRIPTION
1	Typical Elevations, Design Pressures & General Notes
2	Door, Sidelite & Transom Panels & Glazing Details
3	Elevations
4	Horizontal & Vertical Cross Sections (2X Buck)
5	Horizontal Cross Sections (2X Buck)
6	Horizontal & Vertical Cross Sections (1X Buck)
7	Horizontal & Vertical Cross Sections (Direct to Masonry)
8	Horizontal Cross Sections
9	Vertical Cross Sections
10	Buck Anchoring
11	Frame Anchoring
12	Bill of Materials & Components

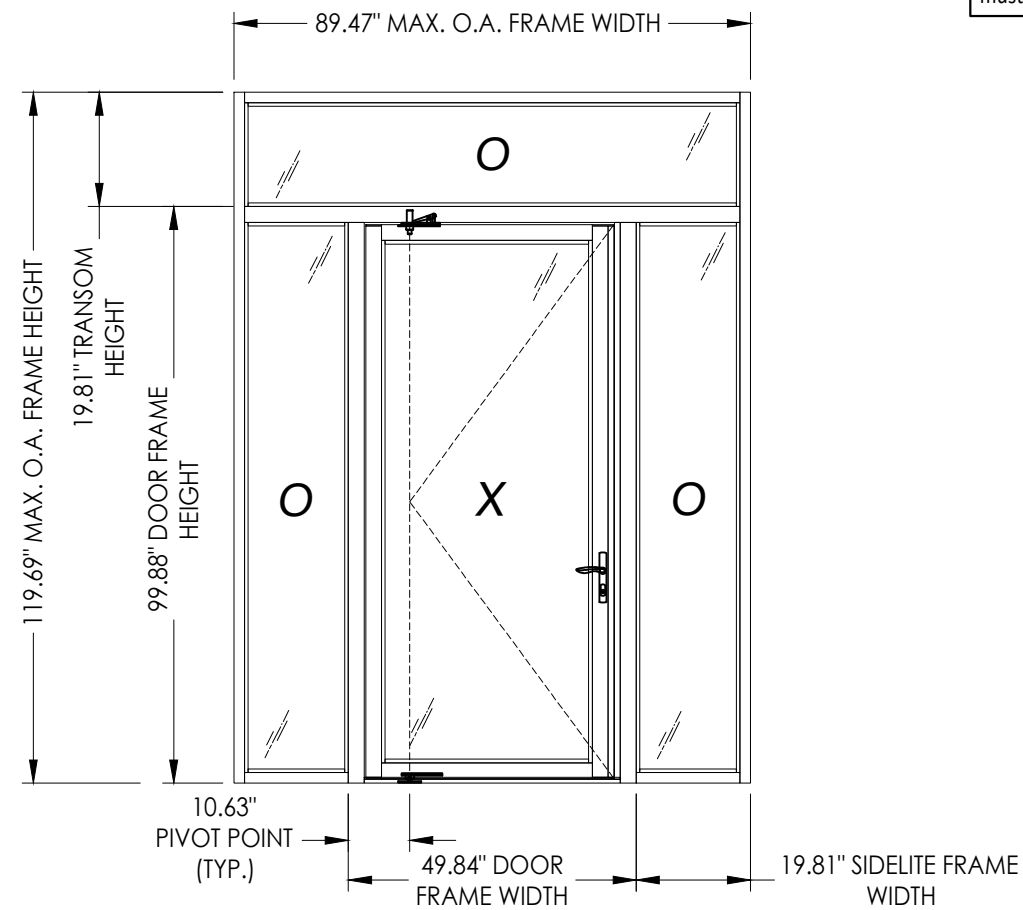
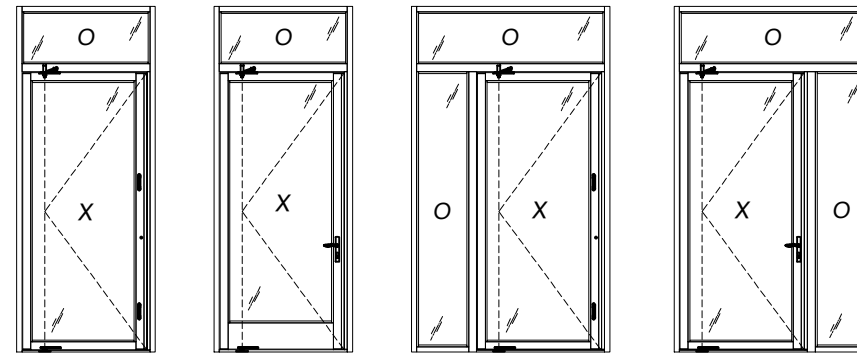

CONFIGURATION	MAX. FRAME DIMENSION	DOOR MAX. D.L.O.	SIDLITE MAX. D.L.O.	TRANSOM MAX. D.L.O.	DESIGN PRESSURE (PSF)	
					POSITIVE	NEGATIVE
	47.97" x 119.69"	35.25" X 89.25"	N/A	43.09" X 16.75"	+50.0	-50.0
	68.72" x 119.69"	35.25" X 89.25"	16.75" X 94.06"	63.84" X 16.75"	+50.0	-50.0
	89.47" x 119.69"	35.25" X 89.25"	16.75" X 94.06"	84.59" X 16.75"	+50.0	-50.0

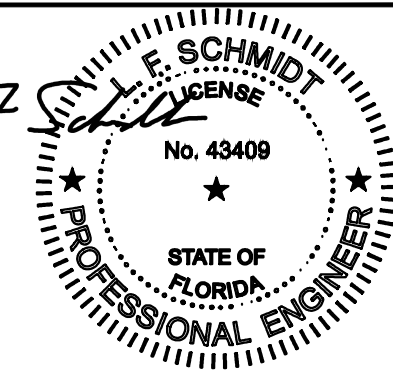

This item has been digitally signed and sealed by L. F. Schmidt, P.E. on the date adjacent to the seal. Printed copies of this document are not considered signed and sealed and the signature must be verified on any electronic copies.

THIS PRODUCT APPROVAL IS VALID ONLY FOR THE STATE OF FLORIDA

Documents Prepared By:
Lyndon F. Schmidt
P.E. No. 43409

RW BUILDING CONSULTANTS, INC.
P.O. Box 230, Valrico, FL 33595
Phone No.: 813.659.9197
FBPE Registry No. 9813

PRODUCT: THERMA TRU
PART OR ASSEMBLY: TYPICAL ELEVATION, DESIGN PRESSURES & GENERAL NOTES

NO.	DATE	BY	REVISIONS

DATE: 2/07/24
SCALE: N.T.S.
DWG. BY: LFS
CHK. BY: RW
DRAWING NO.: FL-46173.11
SHEET 1 OF 12

© 2024 R.W. BUILDING CONSULTANTS INC.

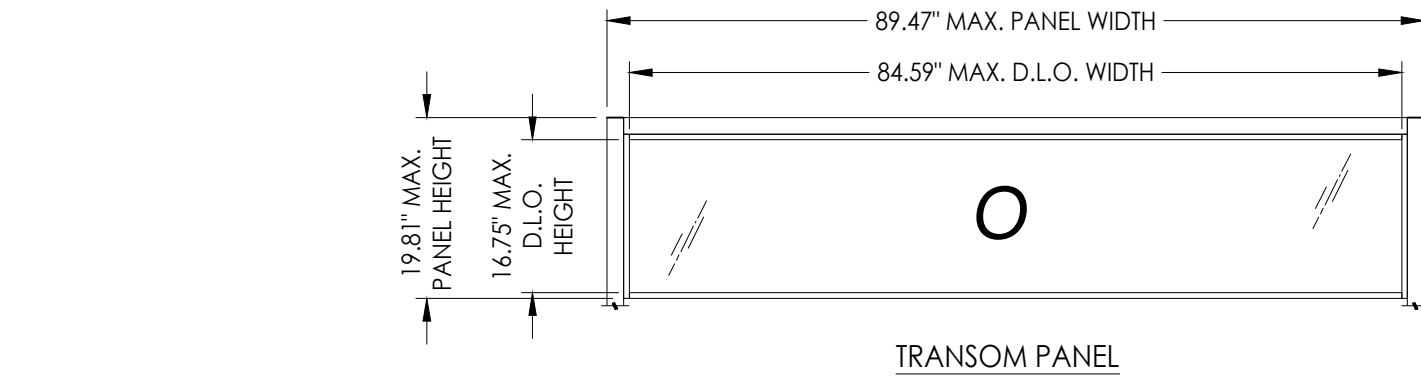

TRANSOM PANEL

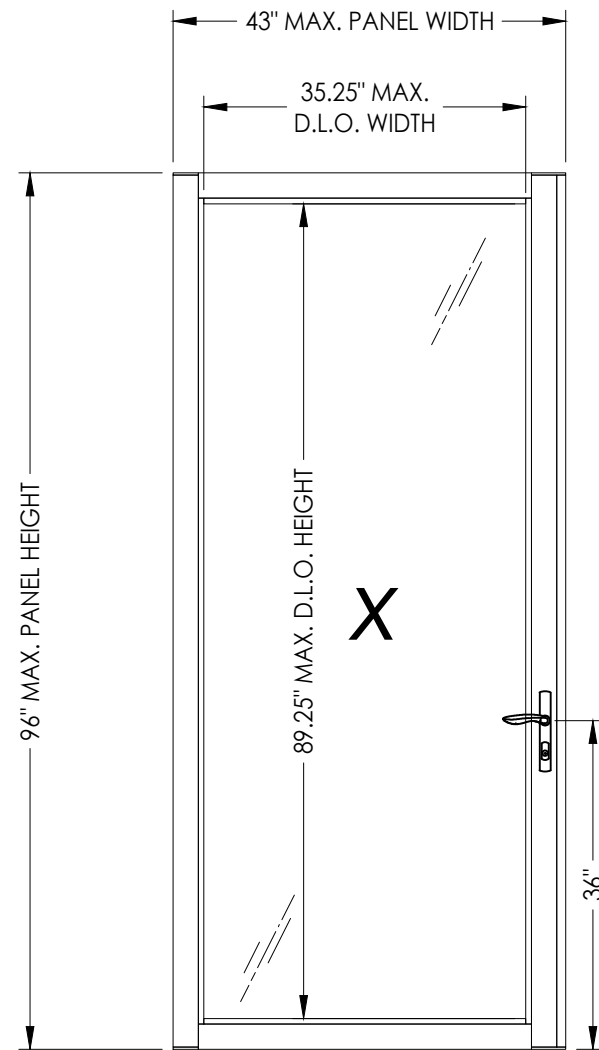

DOOR PANEL

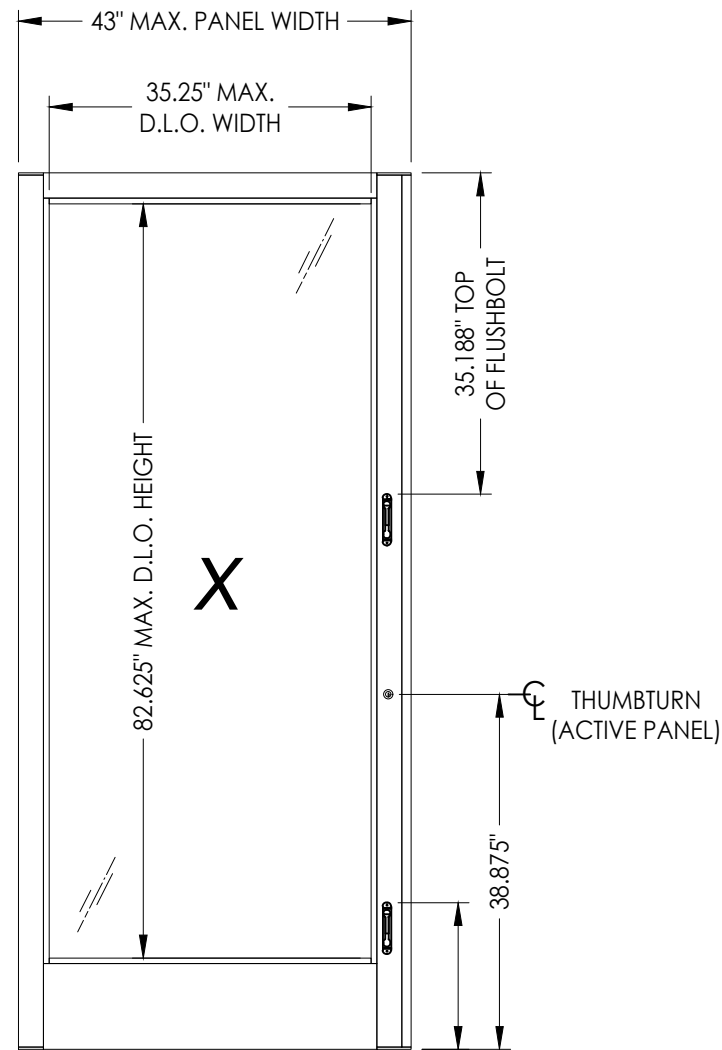

DOOR PANEL

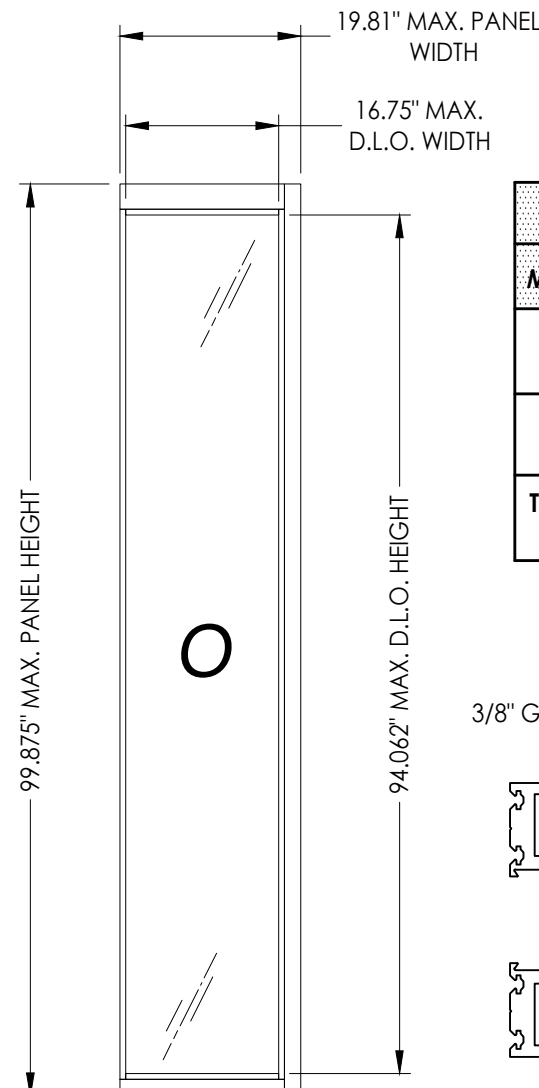

SIDELITE PANEL

HARDWARE TABLE	
MANUFACTURER	MODEL
HOPPE	HOPPE HLS9000 ACTIVE: LEVER w/ 3 pt. LOCK
ADAMS RITE	ACTIVE: THUMBTURN & KEYED CYLINDER MS+ 1890 SERIES DEADBOLT
TERRY HINGE & HARDWARE	ACTIVE: FLUSHBOLTS

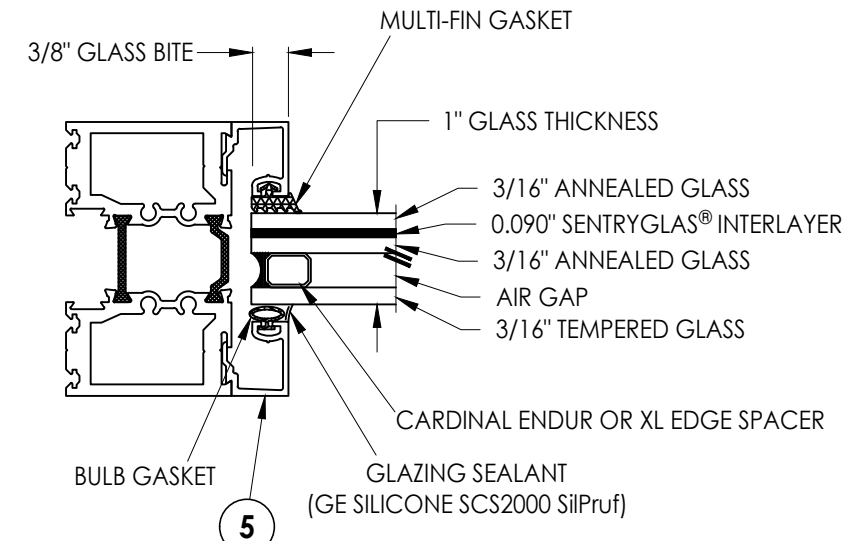

G1 GLAZING DETAIL

NOTE: GLAZING > 36" WIDE REQUIRES AT LEAST TWO (2) SETTING BLOCKS CONFORMING TO FBC SECTION 2411.3.3.1.

Documents Prepared By:
Lyndon F. Schmidt
P.E. No. 43409

RW BUILDING CONSULTANTS, INC.
P.O. Box 230, Valrico, FL 33595
Phone No.: 813.659.9197
FBPE Registry No. 9813

PRODUCT: THERMA-TRU
PART OR ASSEMBLY: DOOR, SIDELITE & TRANSOM PANELS & GLAZING DETAILS

NO.	DATE	BY	REVISIONS

DATE: 2/07/24
SCALE: N.T.S.
DWG. BY: LFS
CHK. BY: RW
DRAWING NO.: FL-46173.11
SHEET 2 of 12

G:\2023 FBC DWGS\Therma-Tru\FL-46173\FL 46173.11.dwg

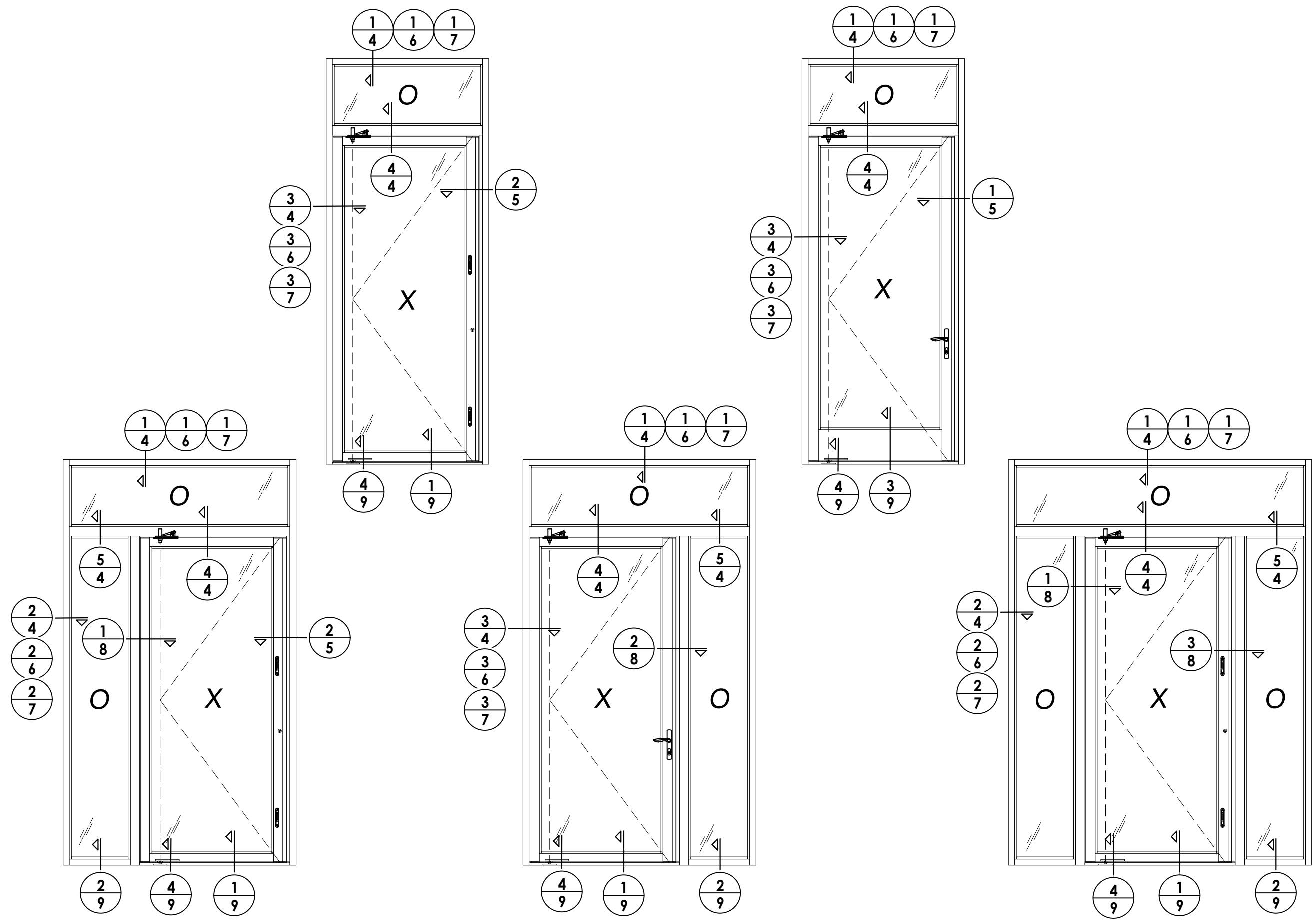

DATE: 2/07/24
 SCALE: N.T.S.
 DWG. BY: LFS
 CHK. BY: RW
 DRAWING NO.: FL-46173.11
 SHEET 3 OF 12

NO.	DATE	BY	REVISIONS

PRODUCT: THERMA-TRU
 PART OR ASSEMBLY: ELEVATIONS

Documents Prepared By:
 Lyndon F. Schmidt
 P.E. No. 43409
 RW BUILDING CONSULTANTS, INC.
 P.O. Box 230, Vairico, FL 33595
 Phone No.: 813.659.9197
 FBPE Registry No. 9813

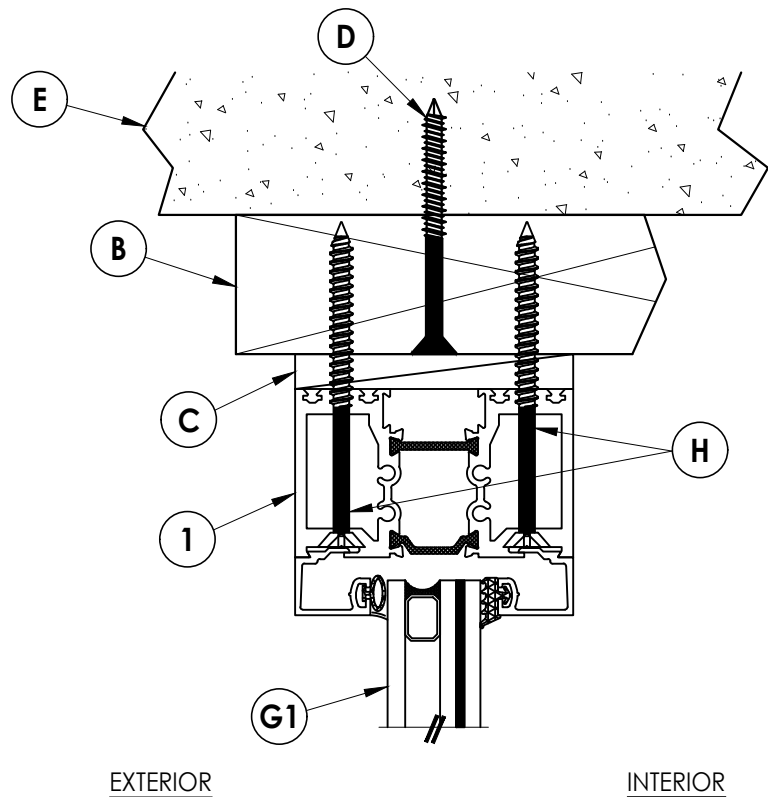

1 **VERTICAL CROSS SECTION**
4 Shown w/ 2X Buck

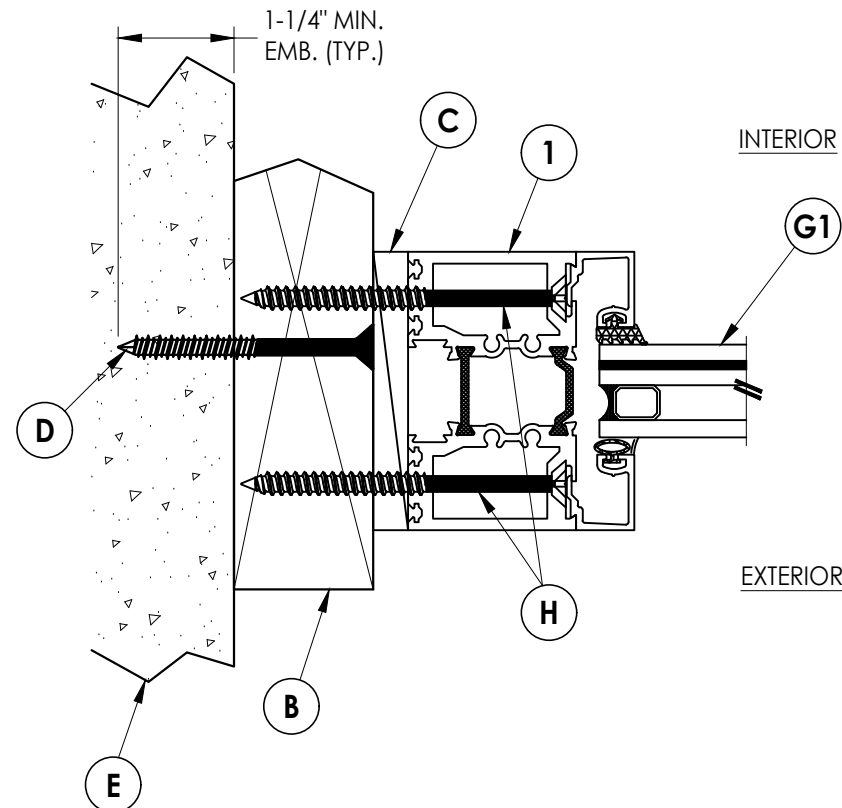

2 **HORIZONTAL CROSS SECTION**
4 Shown w/ 2X Buck

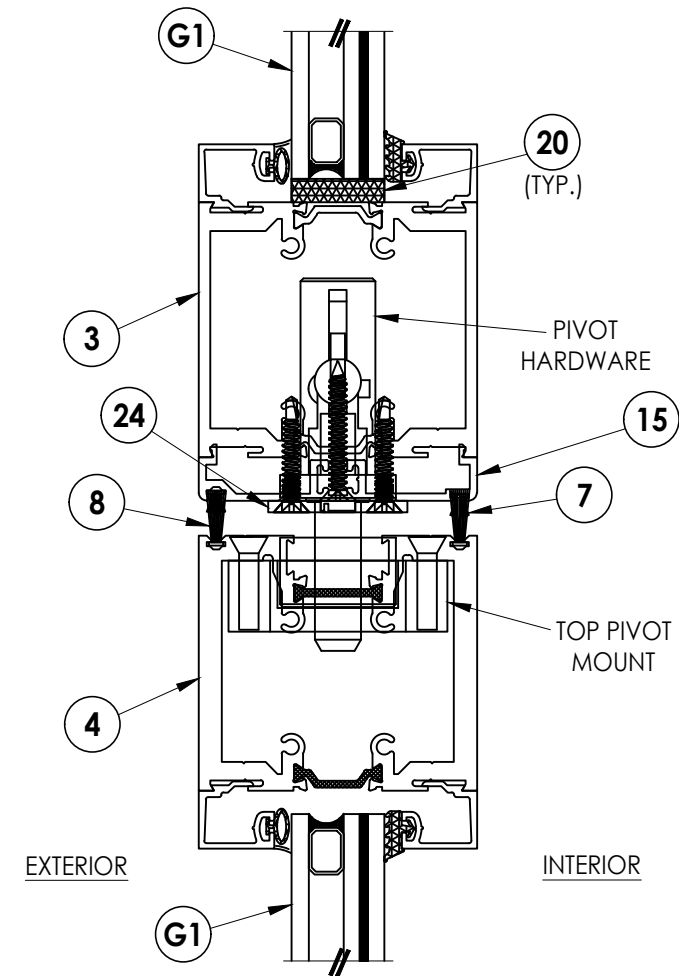

4 **VERTICAL CROSS SECTION**
4

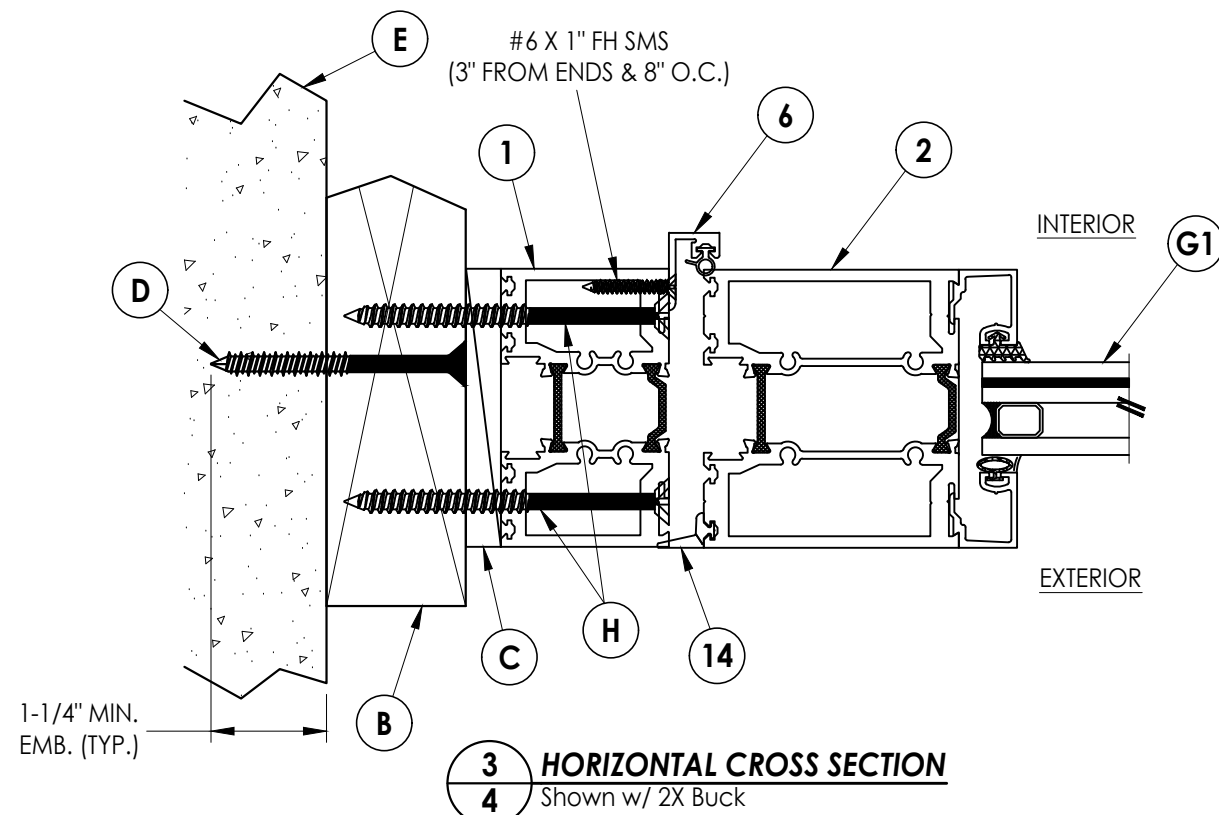

3 **HORIZONTAL CROSS SECTION**
4 Shown w/ 2X Buck

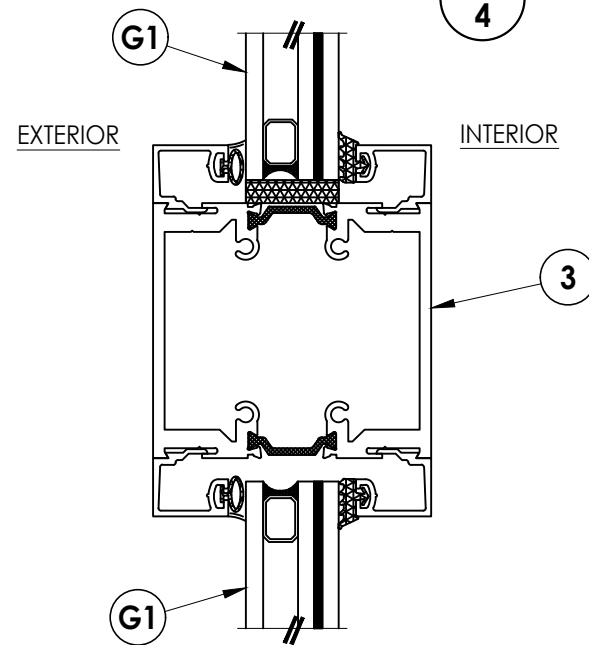

5 **VERTICAL CROSS SECTION**
4

Documents Prepared By:
 Lyndon F. Schmidt
 P.E. No. 43409

RW BUILDING CONSULTANTS, INC.
 P.O. Box 230, Vairico, FL 33595
 Phone No.: 813.659.9197
 FBPE Registry No. 9813

PRODUCT: THERMA-TRU
 PART OR ASSEMBLY:
 HORIZONTAL & VERTICAL
 CROSS SECTIONS (2X BUCK)

NO.	DATE	BY	REVISIONS

DATE: 2/07/24
 SCALE: N.T.S.
 DWG. BY: LFS
 CHK. BY: RW
 DRAWING NO.: FL-46173.11
 SHEET 4 OF 12

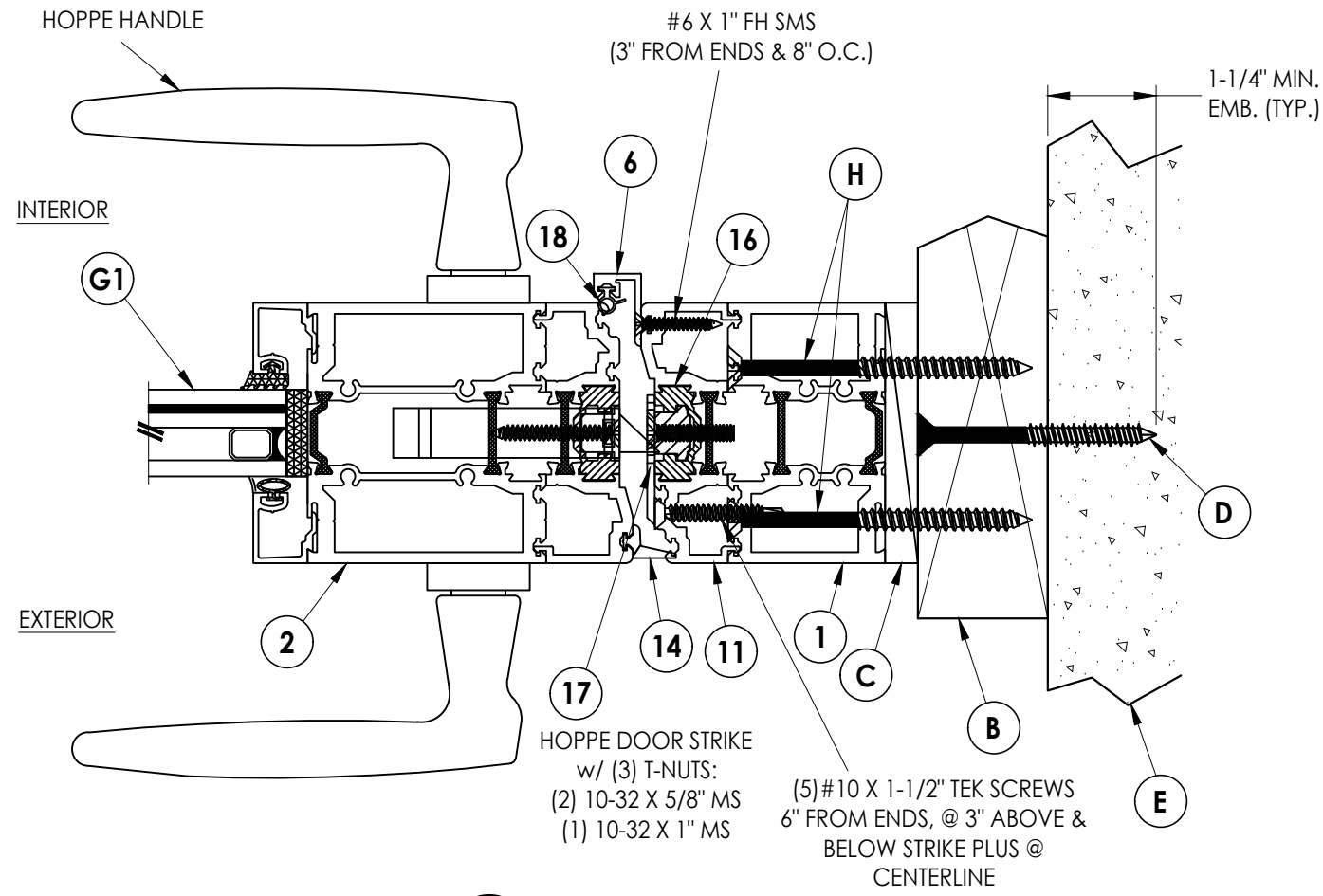

1 HORIZONTAL CROSS SECTION
 5 Shown w/ 2X Buck

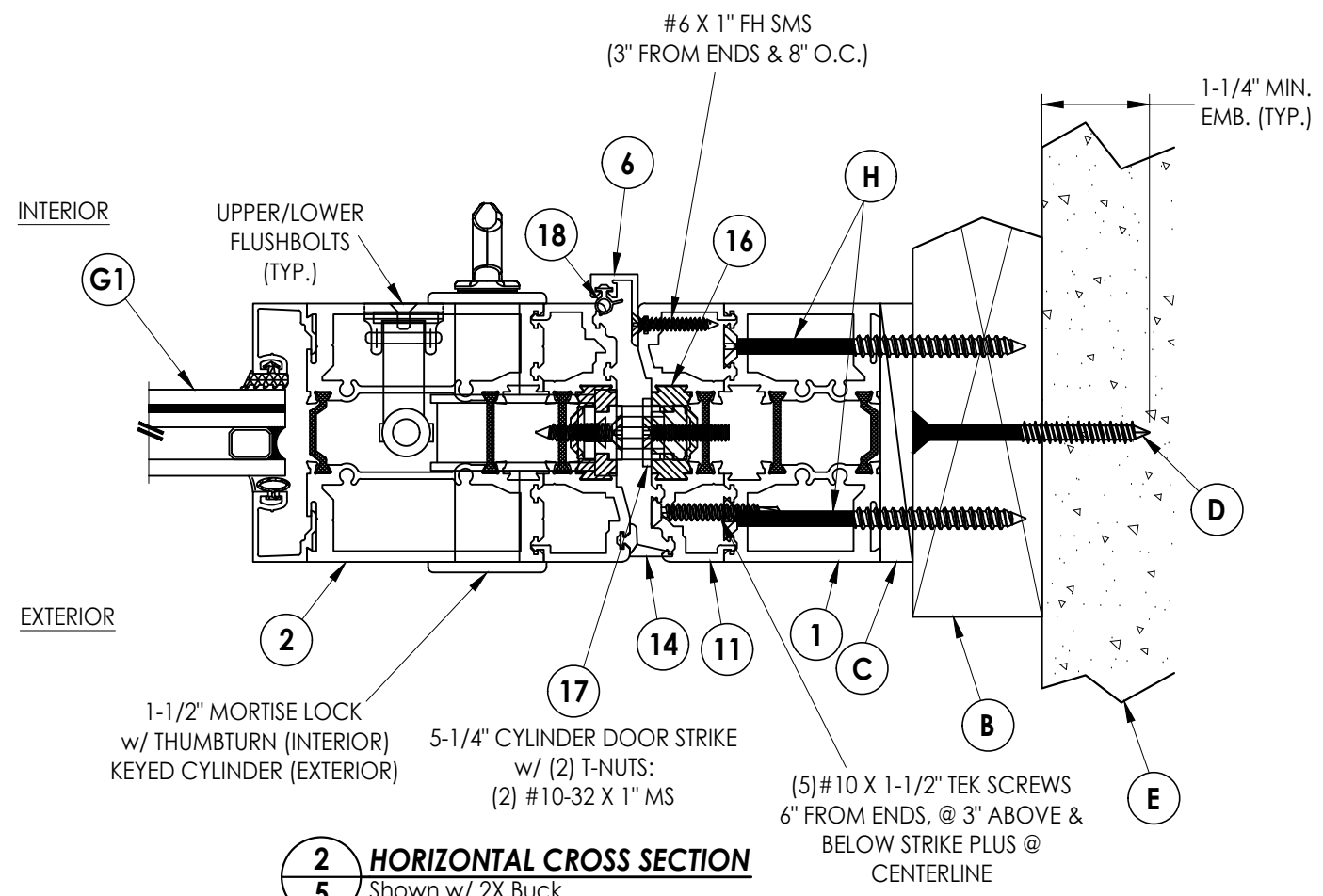

2 HORIZONTAL CROSS SECTION
 5 Shown w/ 2X Buck

Documents Prepared By:
 Lyndon F. Schmidt
 P.E. No. 43409

RW BUILDING CONSULTANTS, INC.
 P.O. Box 230, Vairico, FL 33595
 Phone No.: 813.659.9197
 FBPE Registry No. 9813

PRODUCT: THERMA-TRU
 PART OR ASSEMBLY:
 HORIZONTAL CROSS SECTIONS (2X BUCK)

NO.	DATE	BY	REVISIONS

DATE: 2/07/24
 SCALE: N.T.S.
 DWG. BY: LFS
 CHK. BY: RW
 DRAWING NO.: FL-46173.11
 SHEET 5 OF 12

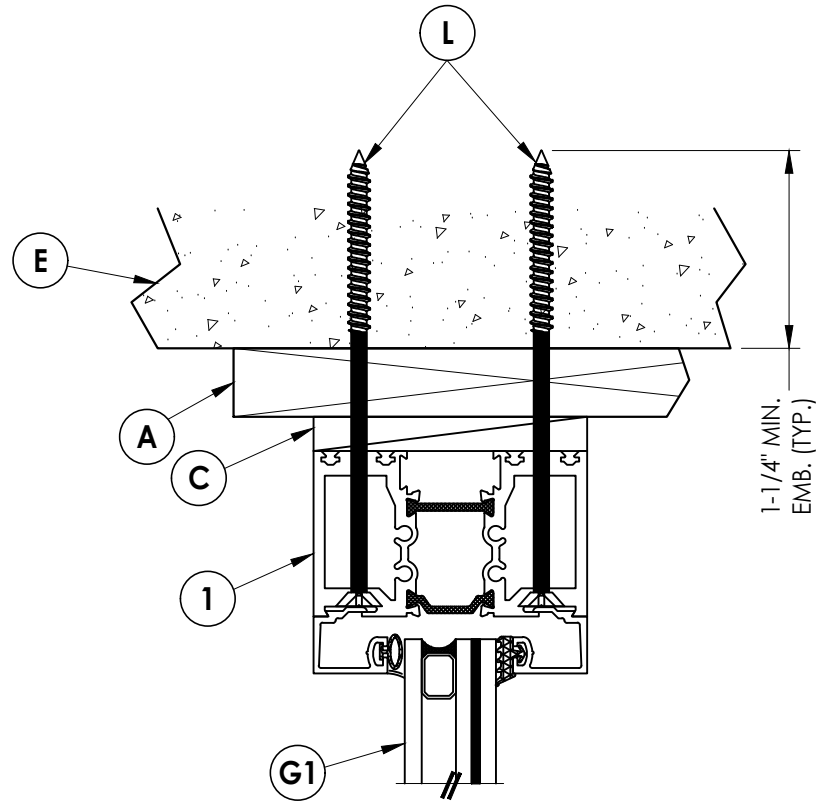

1 VERTICAL CROSS SECTION
6 Shown w/ 1X Buck

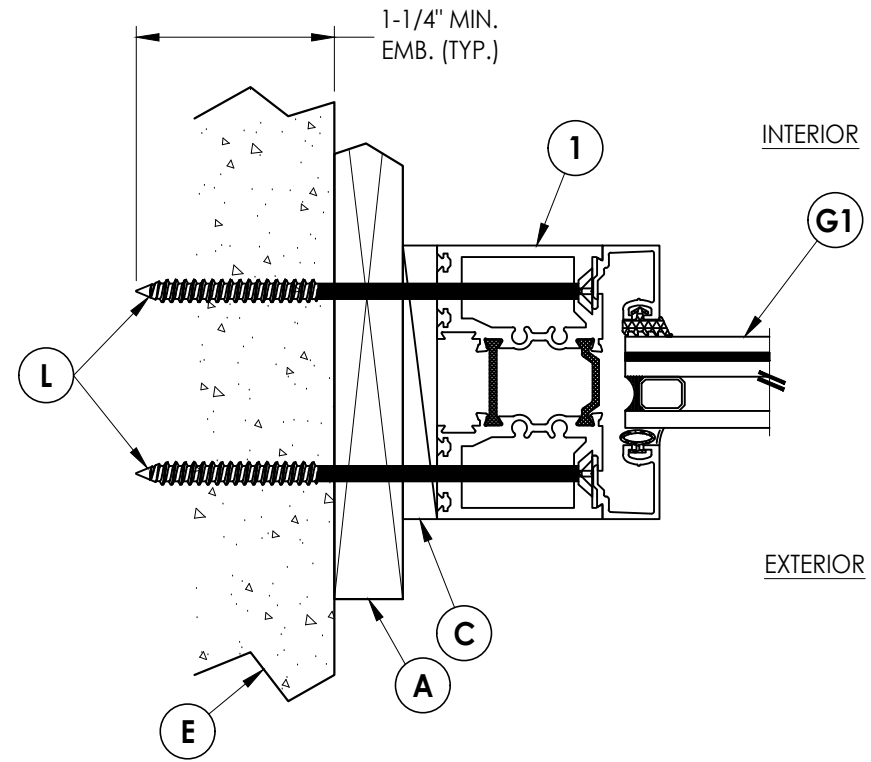

2 HORIZONTAL CROSS SECTION
6 Shown w/ 1X Buck

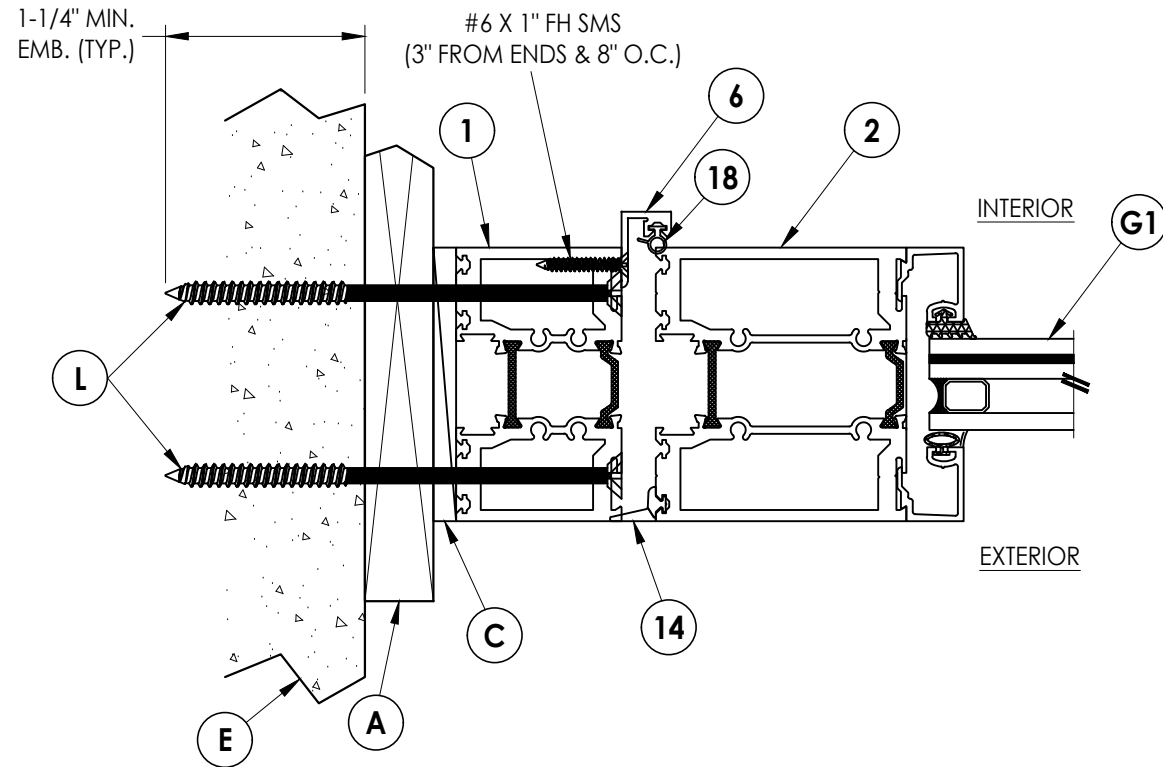

3 HORIZONTAL CROSS SECTION
6 Shown w/ 1X Buck

Documents Prepared By:
 Lyndon F. Schmidt
 P.E. No. 43409

RW BUILDING CONSULTANTS, INC.
 P.O. Box 230, Valrico, FL 33595
 Phone No.: 813.659.9197
 FBPE Registry No. 9813

PRODUCT: THERMA-TRU

PART OR ASSEMBLY:
 HORIZONTAL & VERTICAL
 CROSS SECTIONS (1X BUCK)

NO.	DATE	BY

DATE: 2/07/24
 SCALE: N.T.S.
 DWG. BY: LFS
 CHK. BY: RW
 DRAWING NO.: FL-46173.11
 SHEET 6 OF 12

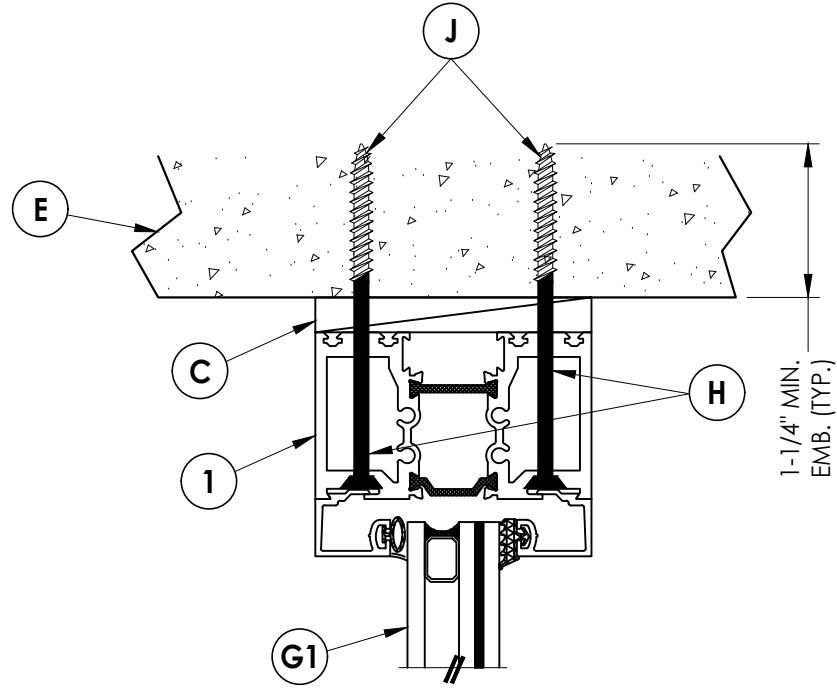

1 **VERTICAL CROSS SECTION**
7 Shown Direct to Masonry

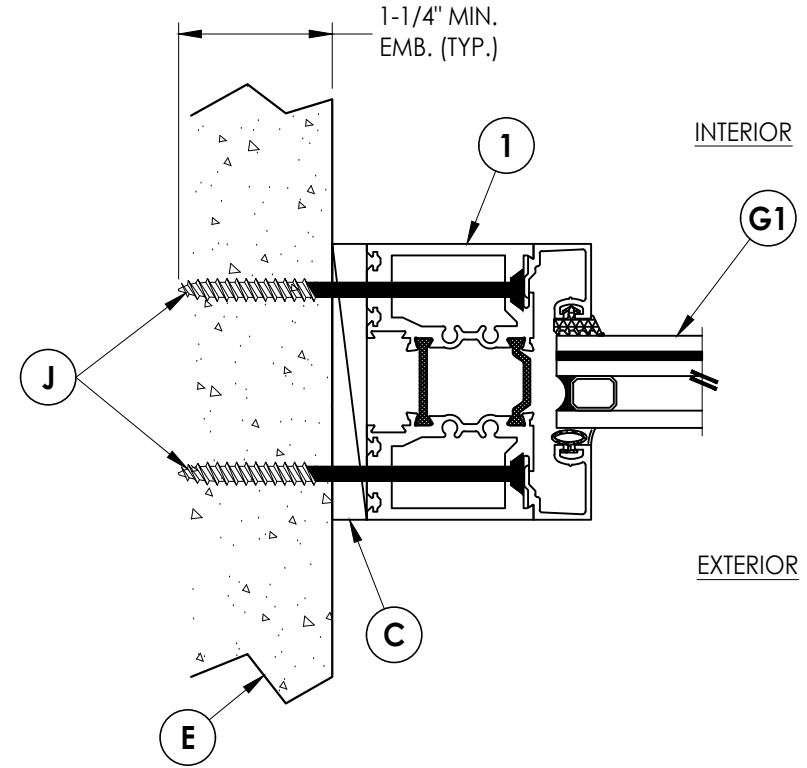

2 **HORIZONTAL CROSS SECTION**
7 Shown Direct to Masonry

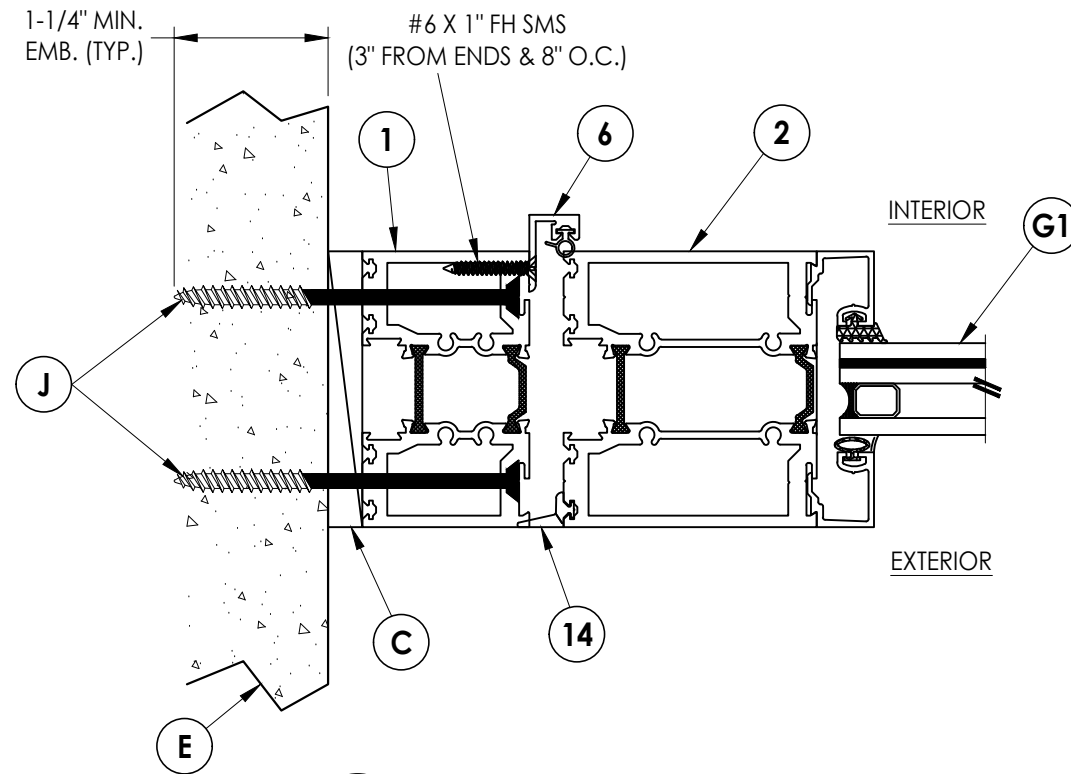

3 **HORIZONTAL CROSS SECTION**
7 Shown Direct to Masonry

Documents Prepared By:
 Lyndon F. Schmidt
 P.E. No. 43409

RW BUILDING CONSULTANTS, INC.
 P.O. Box 230, Valrico, FL 33595
 Phone No.: 813.659.9197
 FBPE Registry No. 9813

PRODUCT: THERMA-TRU

PART OR ASSEMBLY:
 HORIZONTAL & VERTICAL CROSS
 SECTIONS (DIRECT TO MASONRY)

NO.	DATE	BY	REVISIONS

DATE: 2/07/24
 SCALE: N.T.S.
 DWG. BY: LFS
 CHK. BY: RW
 DRAWING NO.:
 FL-46173.11
 SHEET 7 OF 12

G:\2023 FBC DWGS\Therma-Tru\FL-46173\FL 46173.11.dwg

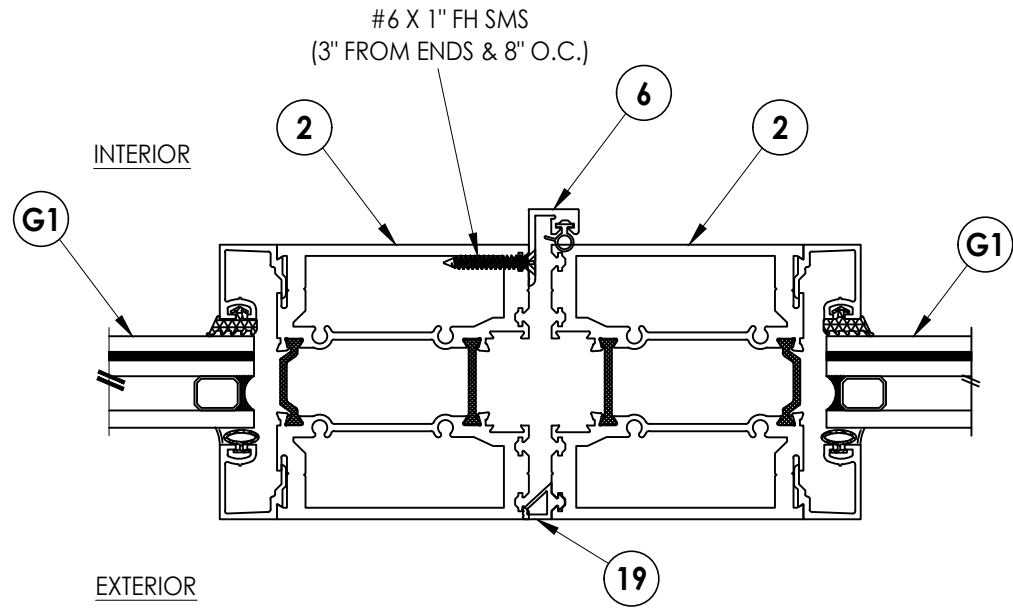

1
8 HORIZONTAL CROSS SECTION

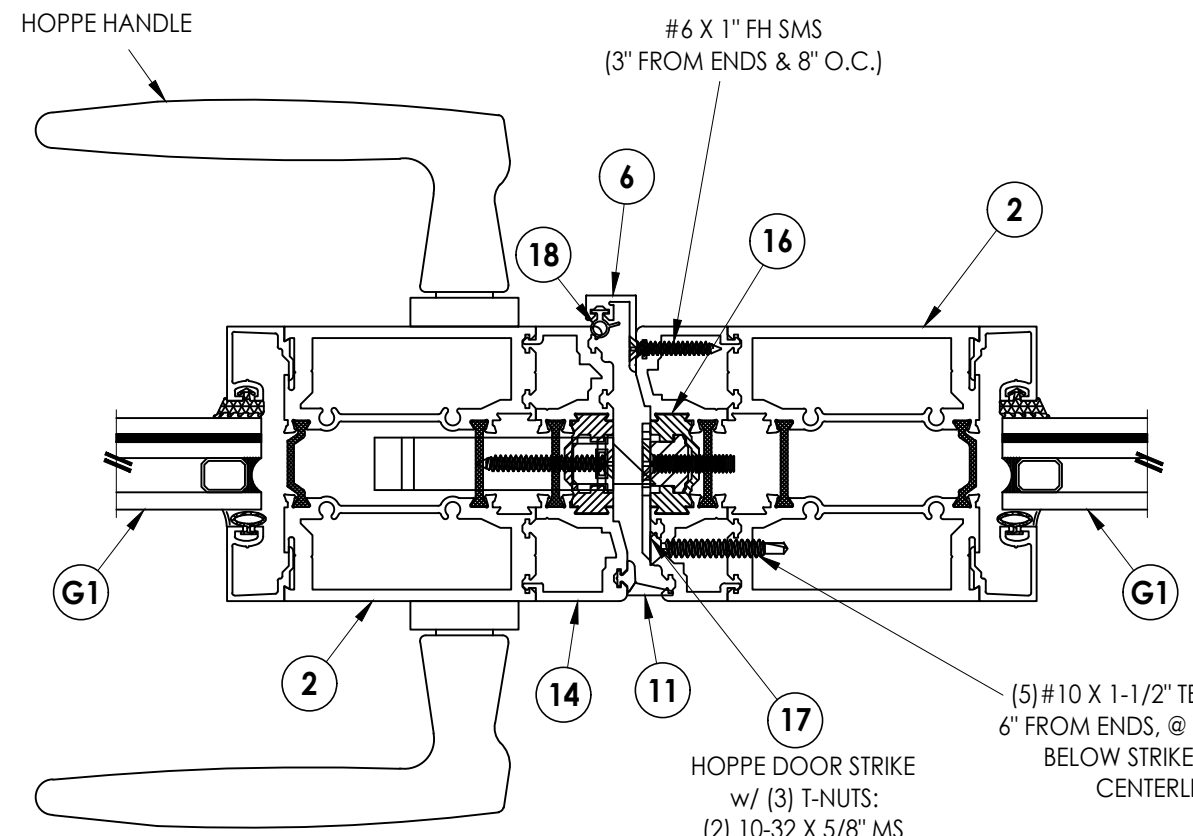

2
8 HORIZONTAL CROSS SECTION

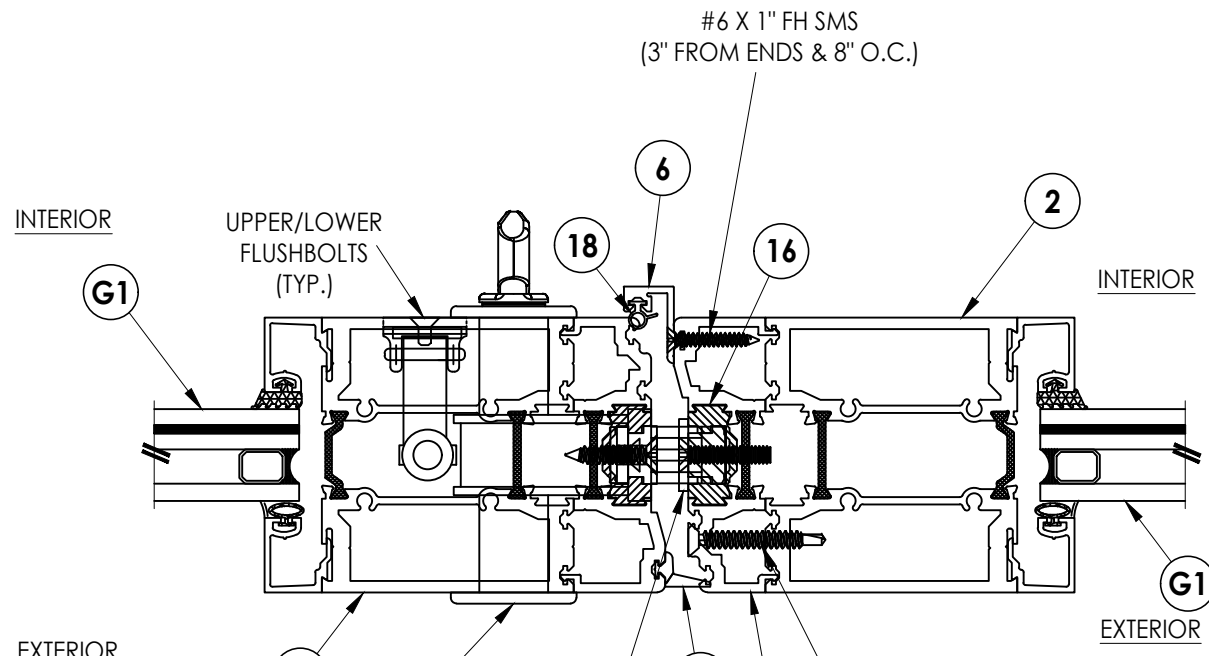

3
8 HORIZONTAL CROSS SECTION

Documents Prepared By:
Lyndon F. Schmidt
P.E. No. 43409

RW BUILDING CONSULTANTS, INC.
P.O. Box 230, Valrico, FL 33595
Phone No.: 813.659.9197
FBPE Registry No. 9813

PRODUCT:	Therma-TRU
PART OR ASSEMBLY:	HORIZONTAL CROSS SECTIONS

NO.	DATE	BY	REVISIONS

DATE:	2/07/24
SCALE:	N.T.S.
DWG. BY:	LFS
CHK. BY:	RW
DRAWING NO.:	FL-46173.11
SHEET	8 OF 12

© 2024 R.W. BUILDING CONSULTANTS INC.

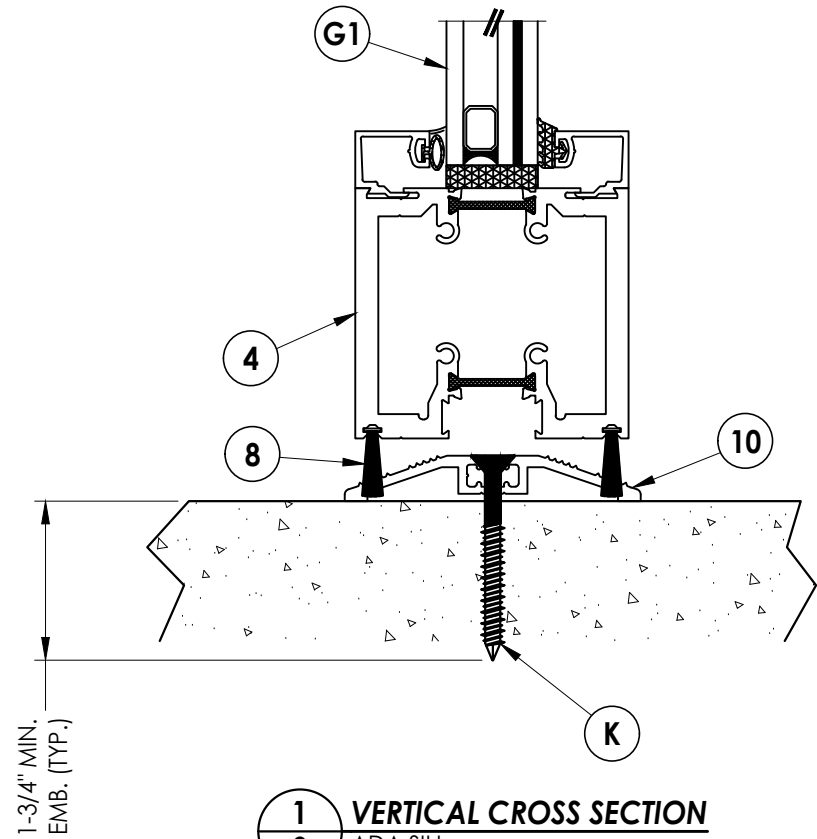

1
9 VERTICAL CROSS SECTION
ADA SILL

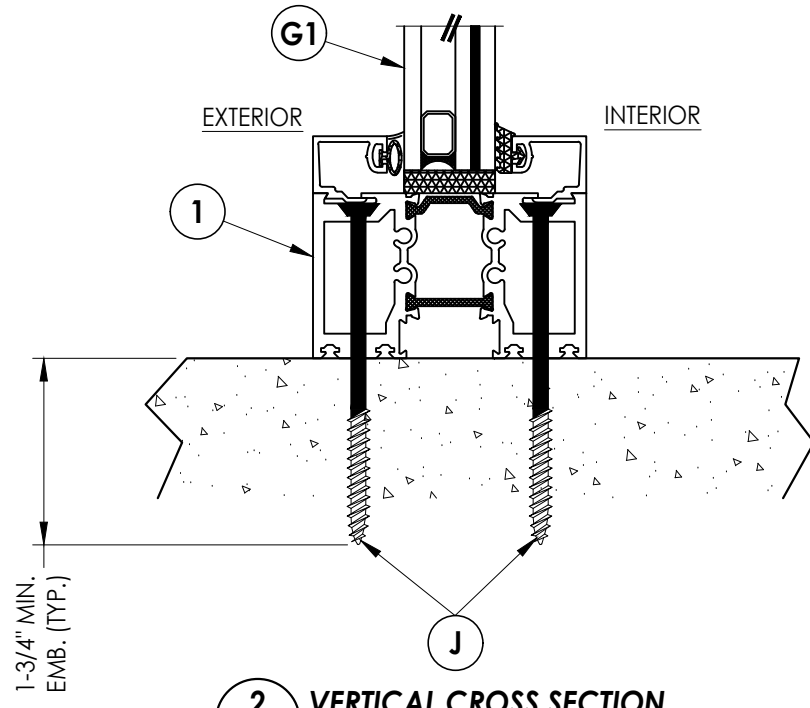

2
9 VERTICAL CROSS SECTION

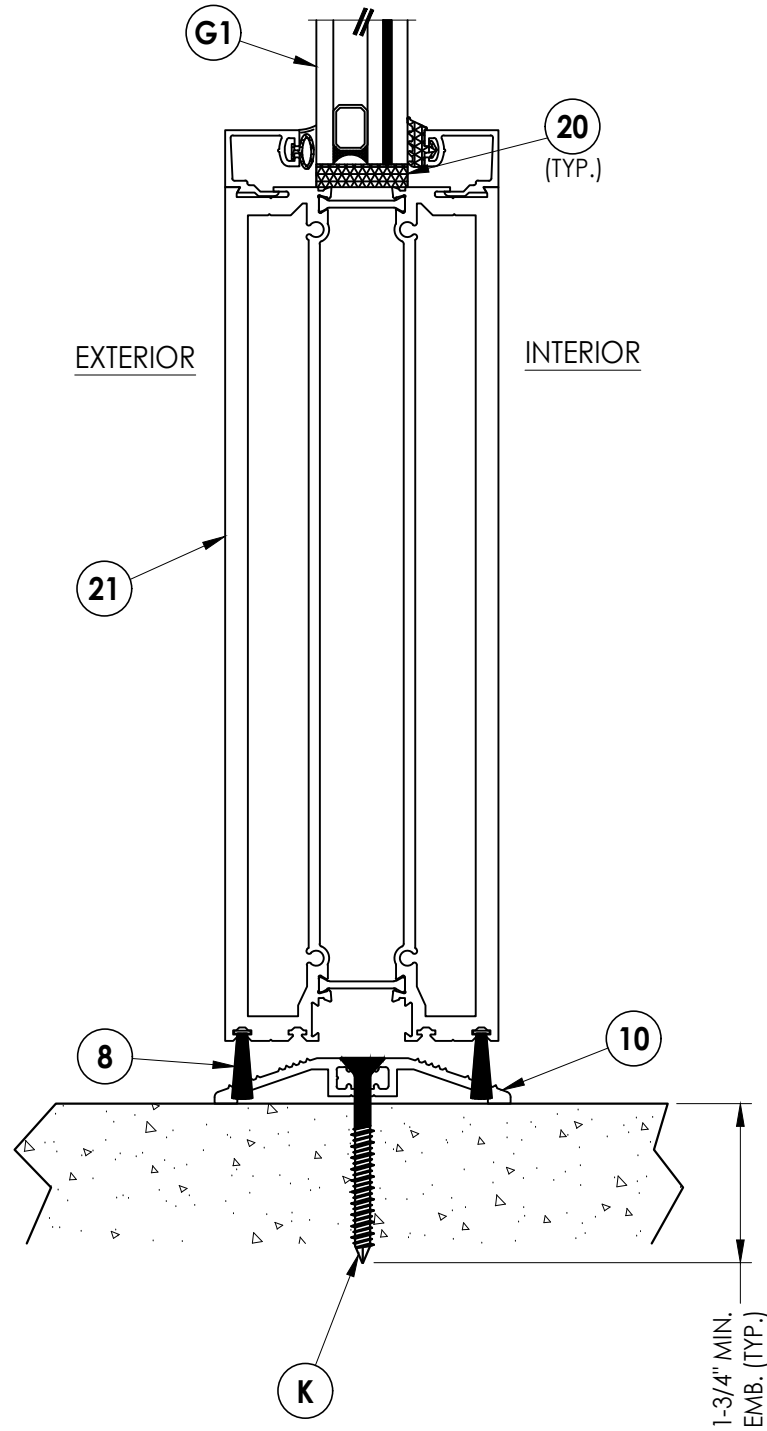

3
9 VERTICAL CROSS SECTION

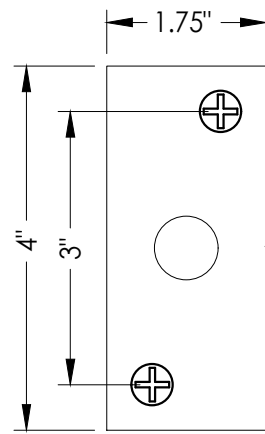

PIVOT HINGE FLOOR PLATE PLAN VIEW

PIVOT STRIKE PLATE (0.25" X 1.75" X 4") ATTACHED
w/ (2) 1/4" Ø X 2-3/4" DeWALT ULTRACON+
CONCRETE SCREWS @ OPPOSITE CORNERS
(3" MIN. O.C. SPACING & 2-1/2" MIN. EDGE DISTANCE)

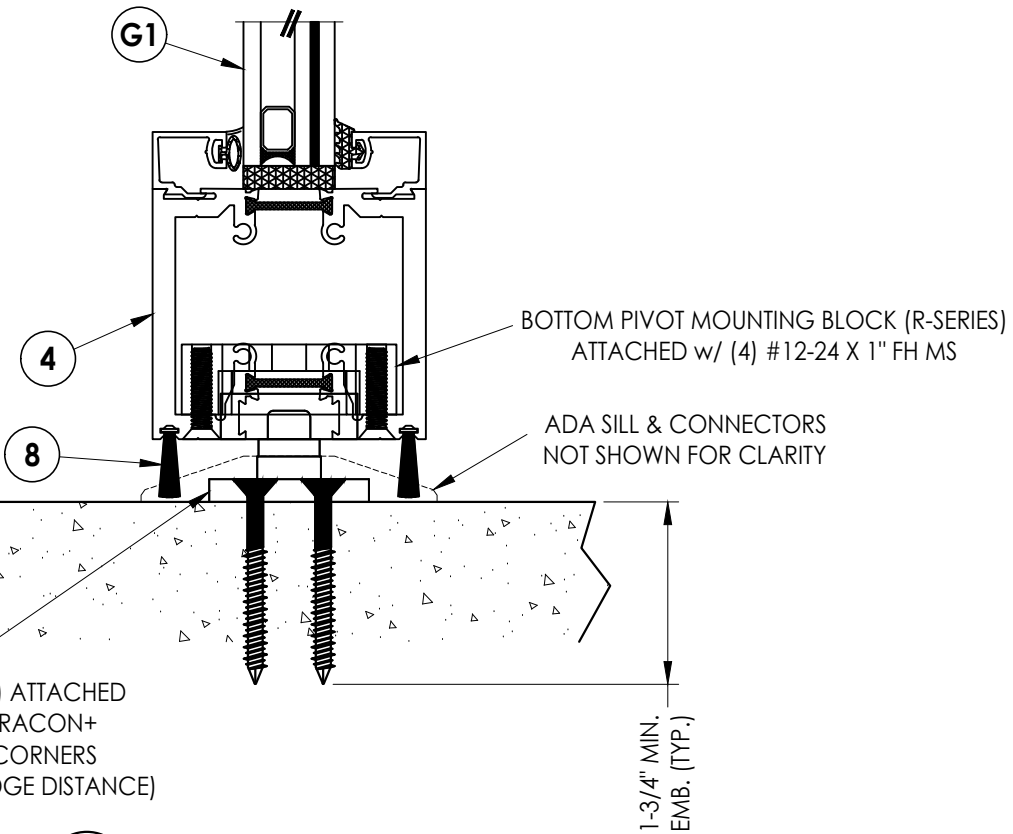

4
9 VERTICAL CROSS SECTION
@ PIVOT STRIKE

Documents Prepared By:
Lyndon F. Schmidt
P.E. No. 43409

RW BUILDING CONSULTANTS, INC.
P.O. Box 230, Valrico, FL 33595
Phone No.: 813.659.9197
FBPE Registry No. 9813

PRODUCT: THERMA-TRU

PART OR ASSEMBLY:
VERTICAL CROSS SECTIONS

NO.	DATE	BY

DATE: 2/07/24

SCALE: N.T.S.

DWG. BY: JK

CHK. BY: RW

DRAWING NO.: FL-46173.11

SHEET 9 OF 12

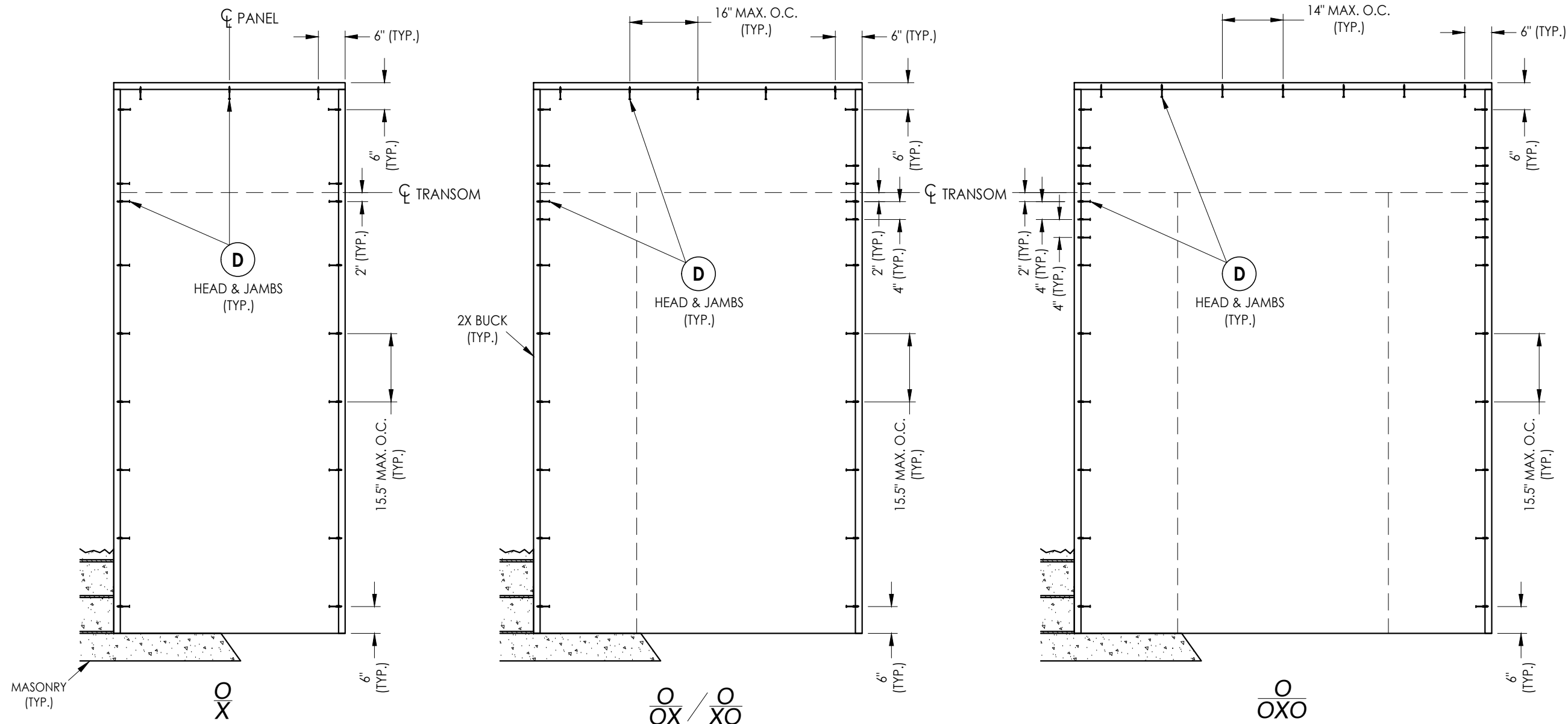

2X BUCK ANCHORING

CONCRETE ANCHOR NOTES:

1. Concrete anchor locations at the corners may be adjusted to maintain the min. edge distance to mortar joints.
2. Concrete anchor locations noted as "MAX. ON CENTER" must be adjusted to maintain the min. edge distance to mortar joints, additional concrete anchors may be required to ensure the "MAX. ON CENTER" dimension are not exceeded.
3. Concrete anchor table:

ANCHOR TYPE	ANCHOR SIZE	MIN. EMBEDMENT	MIN. CLEARANCE TO MASONRY EDGE	MIN. CLEARANCE TO ADJACENT ANCHOR
ITW TAPCON®	1/4"	1-1/4" 1-3/4" (SILL)	2"	4"
DeWALT ULTRACON®	1/4"	1-1/4" 1-3/4" (SILL)	1"	4"

WOOD SCREW INSTALLATION NOTES:

1. Maintain a minimum 5/8" edge distance, 1" end distance, & 1" o.c. spacing of wood screws to prevent the splitting of wood.

Documents Prepared By:
Lyndon F. Schmidt
P.E. No. 43409

RW
BUILDING CONSULTANTS, INC.
P.O. Box 230, Vairico, FL 33595
Phone No.: 813.659.9197
FBPE Registry No. 9813

PRODUCT: THERMA TRU

PART OR ASSEMBLY:
BUCK ANCHORING

NO.	DATE	BY

DATE: 2/07/24

SCALE: N.T.S.

DWG. BY: JK

CHK. BY: RW

DRAWING NO.:
FL-46173.11

SHEET 10 OF 12

NOTE: ALL ANCHORS SHOWN ARE STAGGERED EXCEPT FOR THE ADA SILL ANCHORS (SEE CROSS-SECTIONS)

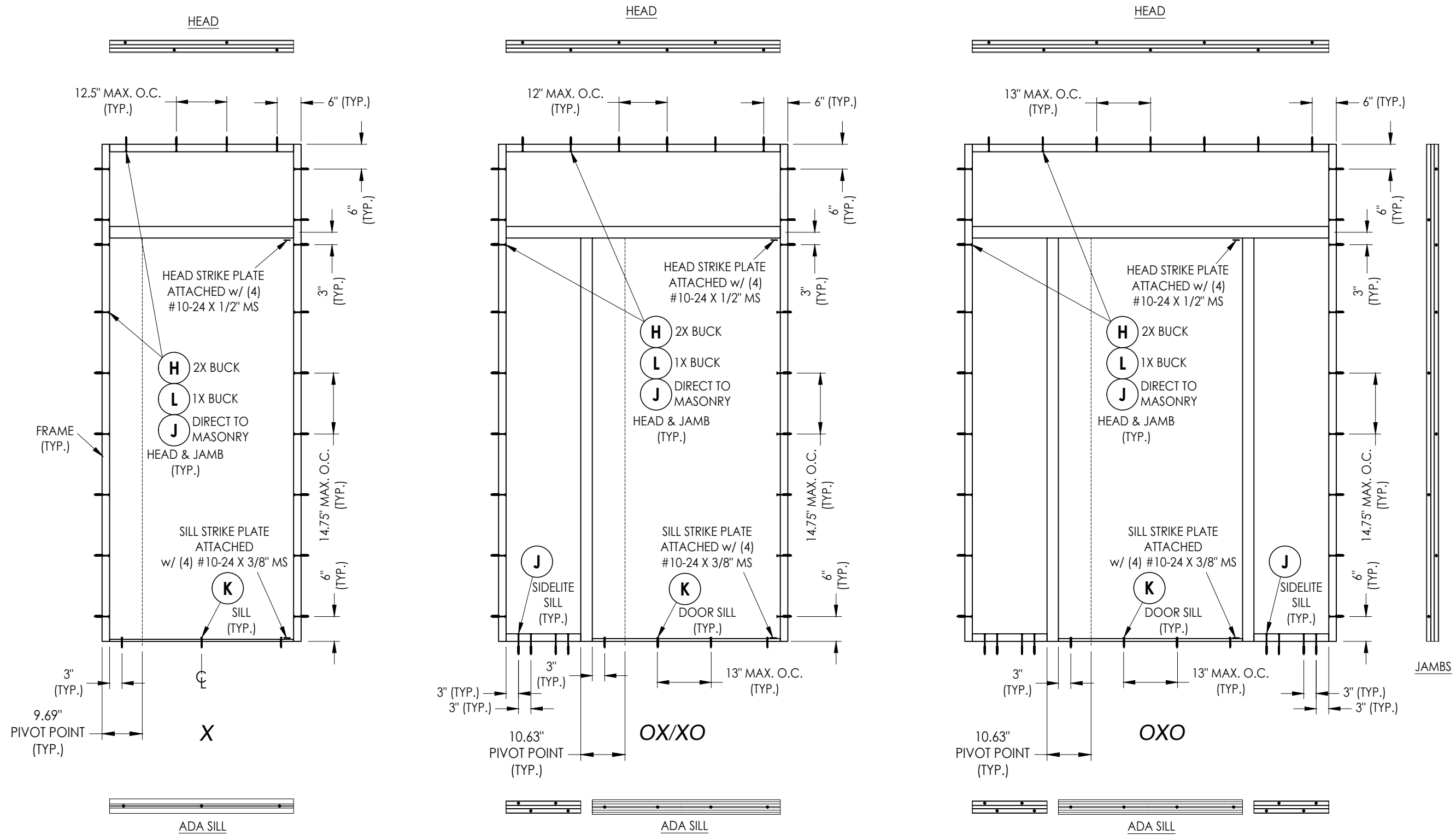

FRAME ANCHORING

Documents Prepared By:
Lyndon F. Schmidt
P.E. No. 43409

RW BUILDING CONSULTANTS, INC.
P.O. Box 230, Valrico, FL 33595
Phone No.: 813.659.9197
FBPE Registry No. 9813

PRODUCT:	THERMA TRU
PART OR ASSEMBLY:	FRAME ANCHORING

NO.	DATE	BY

DATE:	2/07/24
SCALE:	N.T.S.
DWG. BY:	JK
CHK. BY:	RW
DRAWING NO.:	FL-46173.11
SHEET	11 of 12

BILL OF MATERIALS		
ITEM	DESCRIPTION	MATERIAL
A	1X BUCK (SG >= 0.42)	WOOD
B	2X BUCK (SG >= 0.42)	WOOD
C	3/8" MAX. SHIM SPACE	-
D	1/4" X 2-3/4" PFH DeWALT OR ITW CONCRETE SCREW	STEEL
E	MASONRY - 3,000 PSI MIN. CONCRETE CONFORMING TO ACI 301 OR HOLLOW BLOCK CONFORMING TO ASTM C90	CONCRETE
H	#14 X 3-1/2" FH SMS (1-1/4" MIN. EMBEDMENT)	S.S.
J	1/4" X 3-3/4" PFH DeWALT OR ITW CONCRETE SCREW	STEEL
K	1/4" X 2-1/4" PFH DeWALT OR ITW CONCRETE SCREW	STEEL
L	1/4" X 5" PFH DeWALT OR ITW CONCRETE SCREW	STEEL
1	LT NARROW FRAME	6063-T6 ALUM
2	LT FRAME	6063-T6 ALUM
3	MULLION	6063-T6 ALUM
4	PIVOT FRAME	6063-T6 ALUM
5	1/4" GLASS STOP	6063-T6 ALUM
6	SLIDE-IN DOOR STOP	6063-T5 ALUM
7	FELT WEATHERSTRIP	-
8	3/4" BRUSH WEATHERSTRIP	-
10	ADA SILL	6063-T5 ALUM
11	SWING DOOR ADAPTER	6063-T6 ALUM
14	DOOR SWEEP FOAM GASKET	-
15	DOOR ADAPTER	6063-T6 ALUM
16	16mm EUROGROOVE	-
17	HOPPE DOOR STRIKE	S.S.
18	BULB GASKET	-
19	DOOR GASKET	-
20	SETTING BLOCK	-
21	DOOR BOTTOM PANEL	6063-T5 ALUM
24	STRIKE PLATE (@ HEAD)	S.S.

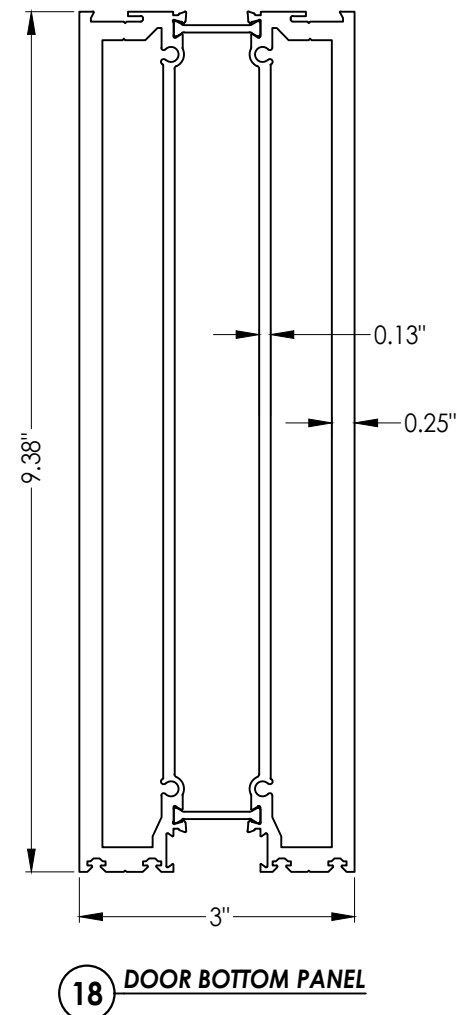
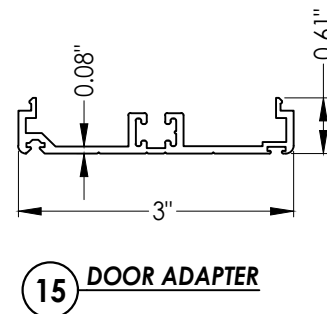
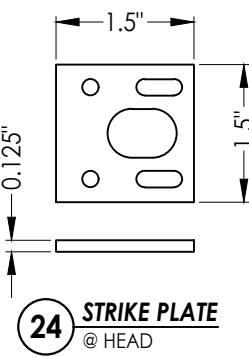
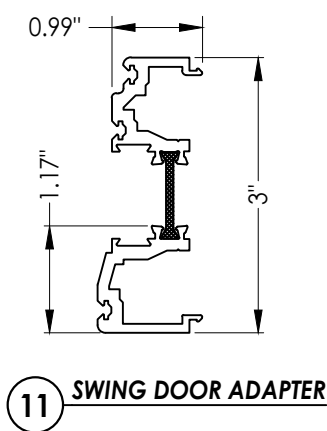
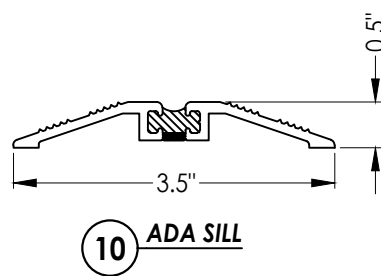
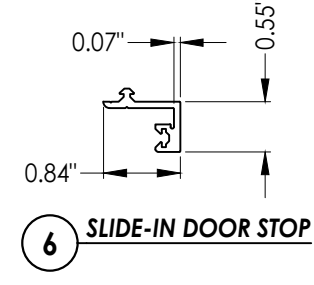
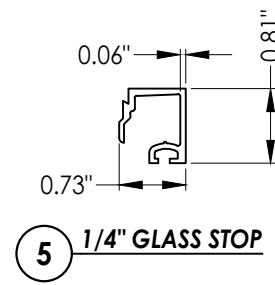
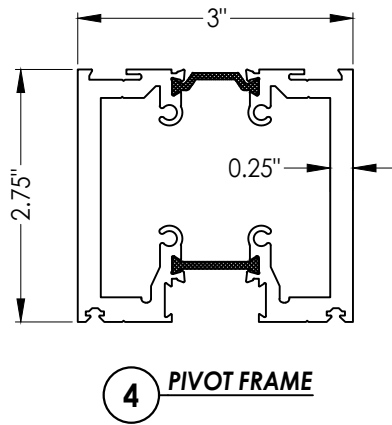
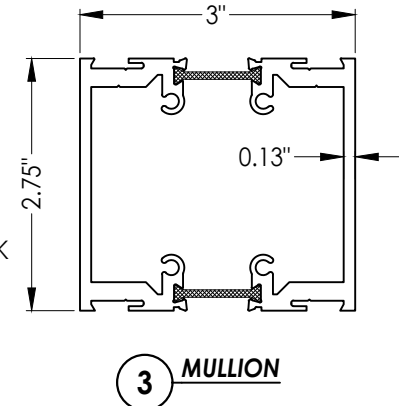
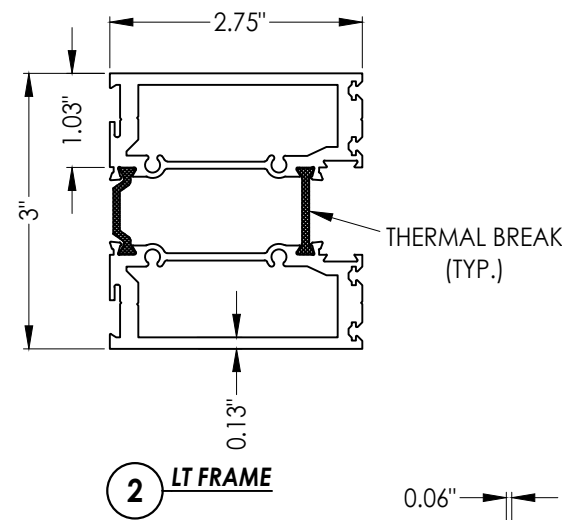
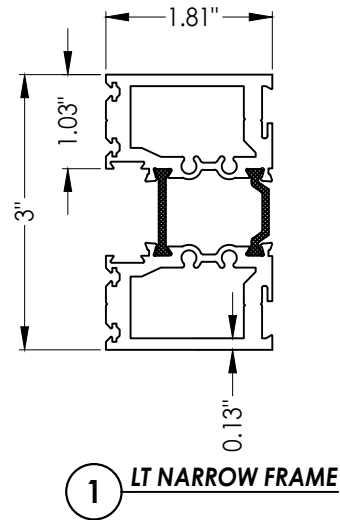

Documents Prepared By:
Lyndon F. Schmidt
P.E. No. 43409

RW BUILDING CONSULTANTS, INC.
P.O. Box 230, Valrico, FL 33595
Phone No.: 813.659.9197
FBPE Registry No. 9813

PRODUCT: THERMA TRU
PART OR ASSEMBLY: BILL OF MATERIAL & COMPONENTS

NO.	DATE	BY	REVISIONS

DATE: 2/07/24
SCALE: N.T.S.
DWG. BY: JK
CHK. BY: RW
DRAWING NO.: FL-46173.11
SHEET 12 OF 12